

# Third Grade April Break Packet

Due: April 29<sup>th</sup>, 2019



Name \_\_\_\_\_



Read the play. Then answer the questions that follow.

## Excerpt from *The Secret Garden*

*from a novel by Frances Hodgson Burnett*

*adapted by David C. Jones, Plays, The Drama Magazine for Young People*

*Mary Lennox is a young British girl who has been living in India. She is sent back to England to live with her uncle, Archibald Craven. Mr. Craven lives in a large house in the country. He is busy and pays little attention to Mary. She is left to explore the house and its many gardens on her own.*

### Characters

MARY LENNOX, a young girl

BEN WEATHERSTAFF, a gardener

DICKON SOWERBY, a young boy

### SCENE 2

1     **SETTING:** The mansion<sup>1</sup> gardens. There are flowerbeds, bushes, etc., around stage. Fence covered with ivy, brambles, etc. is upright.

2     **AT RISE:** BEN WEATHERSTAFF is working with a hoe. MARY enters.

3     **BEN** (*Looking up*): Well, well. You must be Mistress Mary, quite contrary. I've heard all about you.

4     **MARY:** I am not contrary—and who are you?

5     **BEN:** I'm Ben Weatherstaff, the gardener. I've worked for Mr. Craven for many, many years.

6     **MARY:** Well, I think you're rude.

7     **BEN:** Be that as it may, you'd better get used to me. I'm the only one around here—except for Dickon, that is. He spends a lot of time here too.

8     **MARY:** And where's this locked garden I've heard about?

9     **BEN:** Why, you're standing next to it.

10    **MARY:** But where is the entrance?

<sup>1</sup> mansion: a large house

- 11 BEN: Well, the gate is somewhere under all those wild brambles and ivy that have swallowed it up. It's been locked up so long.
- 12 MARY (*Resolutely*): Well, I shall find the entrance and go in there to play.
- 13 BEN: You won't be able to go in without the key.
- 14 MARY (*Surprised*): There's a key? Where is it?
- 15 BEN: No one knows. Mr. Craven took the key one day and threw it as far as he could. No one has ever found it.
- 16 MARY: I'll find it. You'll see.
- 17 BEN (*Wryly*): Well, good luck, Mistress Mary. You'll need it. (*Laughs and exits. After a moment, DICKON enters, carrying crow, fox, and lamb.*)
- 18 DICKON: Hello. You must be Miss Mary.
- 19 MARY: How did you know my name? And who are you?
- 20 DICKON: They call me Dickon. And I know about you because my sister, Martha, told me all about you.
- 21 MARY: Is it true you speak to animals?
- 22 DICKON: Aye. Say hello to my friends. This is Cert, the crow. (*Cawing sound is heard.*) The fox is Captain, and the lamb, Lady. (*Bleating is heard.*)
- 23 MARY: Those are strange names for animals.
- 24 DICKON: It's what they asked to be called.
- 25 MARY (*Scoffing*): Animals and birds can't talk.
- 26 DICKON: Sure they can. You just have to know how to listen. (*Looks offstage*) Look! Here comes my friend, Robin. (*Robin puppet flies in.*)
- 27 ROBIN: Hello, Dickon. Who is your friend?
- 28 MARY (*Astonished*): Why, he does talk!
- 29 DICKON: See? You just have to want to listen to them. (*To ROBIN*) What are you up to, Robin?
- 30 ROBIN: I'm building my nest. Spring is coming, you know, so I'm busy, busy, busy.
- 31 MARY (*Delighted*): Oh, he's so cute and funny. Do you think he would be my friend, too? I have no one to play with.
- 32 DICKON: Of course. You can find lots of friends here. You're just sad and lonely now, but you'll find happiness here, just as you did in India.
- 33 MARY (*Starting to cry*): No. I shall never be happy here. I hate this place. It's horrible! I want to go back to India. (*Runs off*)
- 34 DICKON: She could really use a friend or two, eh, Robin? (*Curtain*)

**Go On**

**31** Read the following sentence from line 11.

Well, the gate is somewhere under all those wild brambles and ivy that have swallowed it up.

The author uses the word "swallowed" to show that

- A the gate is covered with plants and vines
- B plants and vines have eaten through the gate
- C the gate has been ruined from overuse
- D the plants and vines are dangerous

**32** Which sentence from the play lets you know that Mr. Craven does not want anyone to go into the locked garden?

- A "I've worked for Mr. Craven for many, many years."
- B "Well, I shall find the entrance and go in there to play."
- C "You won't be able to go in without the key."
- D "Mr. Craven took the key one day and threw it as far as he could."

**33** Based on the play, which two words **best** describe Mary?

- A funny and kind
- B cruel and unwise
- C friendly and loud
- D lonely and curious

**34** What is the main lesson Dickon wants Mary to learn?

- A Animals make the best friends.
- B Some people can never be happy.
- C Friends are all around you if you listen.
- D Looking for lost things is a waste of time.

**35** Read this sentence from line 32.

You're just sad and lonely now, but you'll find happiness here, just as you did in India.

The word "lonely" has the same root as the word "alone." What does the word "lonely" mean as it is used in this sentence?

- A** having too many friends
- B** wishing someone would go away
- C** wanting to be with other people
- D** needing time to think

**36** How does the ending of this scene help the reader understand the other events in the scene?

- A** It shows that Dickon does not want to be friends with Mary.
- B** It shows that many of Mary's earlier actions were because she is sad.
- C** It shows that Dickon and Ben have always known each other.
- D** It shows that Mary could talk to animals when she lived in India.

**37** What is Mary's point of view about Ben when they first meet?

- A** She doesn't believe he belongs there.
- B** She is sure they will be friends.
- C** She thinks he isn't polite.
- D** She wants to learn more about him.

**STOP**

# Sulka Saves the Savanna

*a folktale from India*

1 Numskull the Lion ruled the savanna<sup>1</sup> with his fierce roar and huge teeth. Unlike other lions, he hunted out of meanness, not just hunger.

2 Numskull picked on the young animals the most. This made all the other animals angry and fearful. Together, the elders decided on a plan. They made Numskull an offer.

3 “Each day,” the elders said, “a few of us will come to you and freely offer ourselves for your dinner.”

4 “Why would I do that?” Numskull roared. “I can eat you anytime I want to.”

5 “Yes, Mighty One, but we can save you from working so hard. You won’t even have to chase us. All we ask is that you let our young ones grow up. When they are big and plump like us, they, too, will freely be your dinner.”

6 Now, Numskull was mean, but he was also lazy. He found the animals’ offer to be acceptable. Each day, he ate a few elders for his evening meal and left the young ones alone.

7 Life went on like that for many months. The children were safe, but little by little the elders disappeared into Numskull’s belly.

8 Finally, it was Sulka’s turn to sacrifice himself. Sulka was scared. He had no desire to be Numskull’s dinner. Still, he had promised. Sulka hopped slowly toward the waiting lion.

9 “This is all you send me? One small, worthless rabbit?” Numskull shouted. “You animals are not honoring your agreement.”

10 “Not so, Great King!” cried Sulka, who was a very clever rabbit. “My four cousins and I were on the way to be your dinner, but a strange lion stopped us. He said he was going to eat us all! We pleaded with him, saying, ‘Don’t eat us, sir. We are already promised as Numskull the Lion’s dinner.’ Then the strange lion said, ‘Who cares about a lion with such a silly name?’ Then he ate my cousins right on the spot!

11 “Then the strange lion pointed at me and said, ‘go tell foolish Numskull that I am the new king. Tell him I will soon come to fight him. Now be off!’

12 “I came straight here to tell you, oh, Mighty Numskull.”

13 Numskull was enraged. “Show me where this fool lives. I will tear him limb from limb!”

<sup>1</sup> savanna: a plain, or flat, grass-covered area

14 Sulka brought Numskull to a deep well. He pointed with a trembling forepaw. "That is where he hides, my king. But be careful. He is fierce!"

15 Numskull peered over the edge of the well. Far below, another lion stared back up at him. "I am the king!" Numskull roared.

16 Then, "I am the king!" roared the lion at the bottom of the well.

17 "How dare you!" Numskull yelled.

18 "How dare you!" the other lion roared back.

19 At that, Numskull leaped into the well, ready to battle the strange lion.

20 But there was no lion. There was only foolish Numskull, angry at his own echo and fighting his reflection.

21 Splash! Numskull was never heard from again, and life on the savanna was peaceful once more.

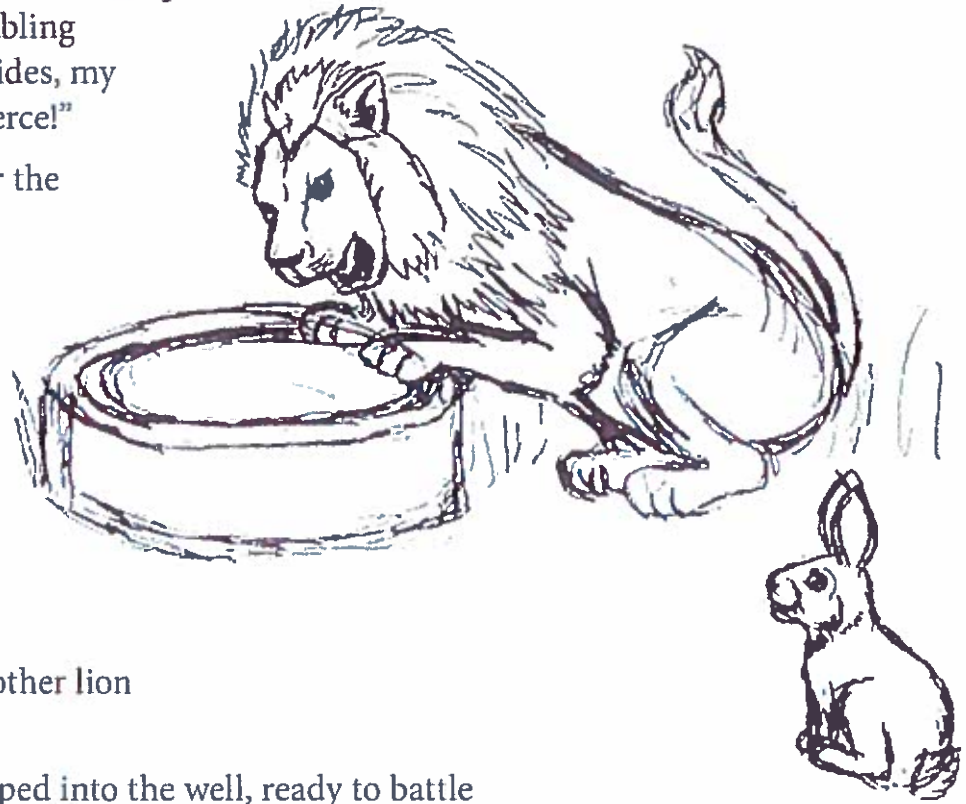



**38** How does Sulka trick Numskull to get him into the well? Use **two** details from the story to support your answer.

Write your answer in complete sentences.

---

---

---

---

---

---

---

---

---

---

**39** How does Numskull most likely feel in the picture? Use **one** detail from the story and **one** detail from the picture to support your answer.

Write your answer in complete sentences.

---

---

---

---

---

---

---

---

---

---

Read the article. Then answer the questions that follow.

# Exotic Animals Are Not Pets

by Paula Bender

1 Pets can be divided into two groups. There are **common pets** and there are **exotic pets**. Common pets are animals like cats, dogs, or hamsters. These animals are found in many households and are familiar pets to most people. Exotic pets are animals like snakes, spiders, or parrots. These animals are uncommon pets. The reason exotic animals are uncommon pets is because exotic animals often don't make good pets.

## Is Keeping Exotic Pets Really Fair?

2 People who own exotic pets most likely want to take good care of them. But homes don't always have what exotic pets need for a good life. Think about exotic pets like parrots, tarantulas, and lizards. They must adapt to live in cages or special glass boxes. They can't fly or crawl long distances. This is something they would do in the wild. To many people, this just doesn't seem fair.

## Are Exotic Pets Fun?

3 Owning an exotic pet might seem exciting. But, it will likely not be as much fun as owning a regular pet. For example, a dog can play and go for walks with its owners. It is easy to see when a dog and owner love each other and enjoy spending time together. An exotic pet like a snake might look neat, but it doesn't do much. A snake just can't jump up, wag its tail, and give you a big slobbery kiss like a dog can.

Which Pet Looks  
Like More Fun?



Look at the pictures. Which pet looks like more fun to be around?

**Go On**

## A Bearded Dragon Tank

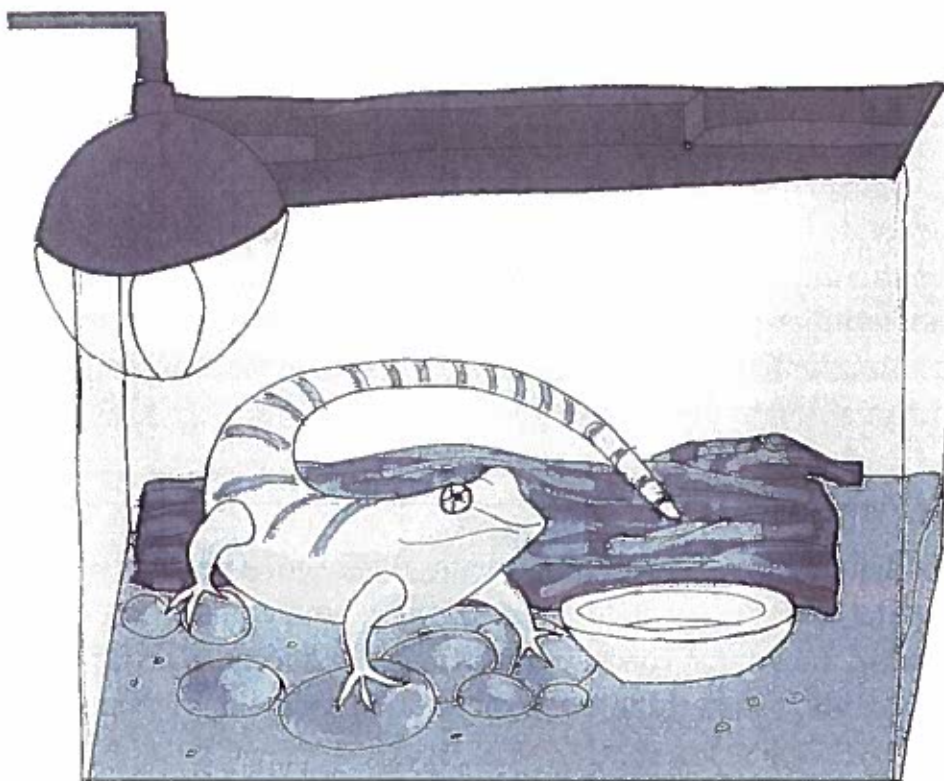

A bearded dragon is a kind of lizard. It needs a large tank, special lights, a heater, things to climb on, and a water bowl in order to stay healthy.

### Can You Give an Exotic Pet Proper Care?

4 Some people think exotic pets don't require much time or care. But it can be very hard to give exotic pets what they need to stay healthy. A snake is a good example. The place where an animal lives is called a habitat. A snake's habitat needs to be kept at just the right temperature for the snake to be healthy and stay alive. The owner must often buy special lights and heaters. Getting the right food for a snake is not easy. If the snake gets sick, it can be tough to find an animal doctor, or veterinarian, who will know how to treat the snake.

### What Should You Look For in a Pet?

5 If you want a happy pet that will make you happy, choose a furry friend like a cat or a dog. Exotic animals should be left in the wild where they belong.

**40** What is the writer's **main** point about exotic animals? Use **two** details from the passage to support your answer.

Write your answer in complete sentences.

---

---

---

---

---

---

***Go On***

## *Planning Page*

You may PLAN your writing for question 41 here if you wish, but do NOT write your final answer on this page. Write your final answer on pages 71 and 72.











Name: \_\_\_\_\_

## Multiple-Step Problems



- a. Craig has a twenty dollar bill. He buys six squirt guns for \$2 each. How much money did Craig have left?

\_\_\_\_\_

- b. Maria invited 4 of her friends over for a water balloon fight in the backyard. At the start of the game, Maria gave each of her friends 2 water balloons. She had one water balloon for herself. How many water balloons did they have altogether?

\_\_\_\_\_

- c. Matthew and his brother Shawn played swimming-pool-basketball. Each basket was worth 3 points. Matthew scored 9 points. Shawn scored 6 points. What is the total number of baskets made during this game?

\_\_\_\_\_

- d. Lauren and Gina's mother told her daughters they can swim in the pool for 20 minutes. First, they swam laps in the pool for 7 minutes. Then they swam underwater for one minute. Then they played water polo for 8 minutes. How much longer can they stay in the pool?

\_\_\_\_\_

# Round & Add

Round each addend to the nearest hundred to estimate the sum. Then find the actual sum.

$$\begin{array}{r} 231 \\ + 145 \\ \hline \end{array}$$



$$\begin{array}{r} + \\ \hline \end{array}$$

$$\begin{array}{r} 457 \\ + 312 \\ \hline \end{array}$$



$$\begin{array}{r} + \\ \hline \end{array}$$

$$\begin{array}{r} 708 \\ + 96 \\ \hline \end{array}$$



$$\begin{array}{r} + \\ \hline \end{array}$$

$$\begin{array}{r} 575 \\ + 448 \\ \hline \end{array}$$



$$\begin{array}{r} + \\ \hline \end{array}$$

$$\begin{array}{r} 166 \\ + 635 \\ \hline \end{array}$$



$$\begin{array}{r} + \\ \hline \end{array}$$

$$\begin{array}{r} 816 \\ + 390 \\ \hline \end{array}$$



$$\begin{array}{r} + \\ \hline \end{array}$$

$$\begin{array}{r} 432 \\ + 729 \\ \hline \end{array}$$



$$\begin{array}{r} + \\ \hline \end{array}$$

$$\begin{array}{r} 124 \\ + 951 \\ \hline \end{array}$$



$$\begin{array}{r} + \\ \hline \end{array}$$

NAME: \_\_\_\_\_

DATE: \_\_\_\_\_

## AREA QUICK CHECK #1

1. What is the area of this shape?

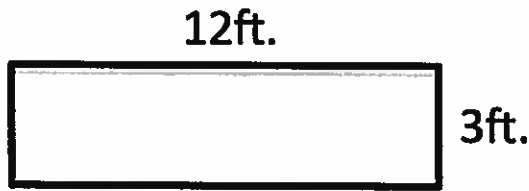

Answer: \_\_\_\_\_

2. Lucy needs to cover her room in carpet. Her room is 9 yards long and 4 yards wide. How much carpet does she need to cover the area of her room?

Answer: \_\_\_\_\_

3. What is the area of this shape?

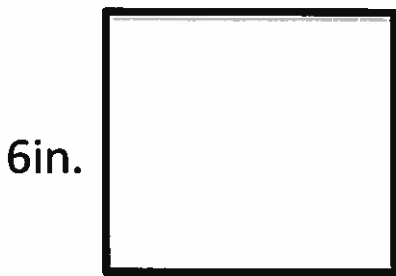

Answer: \_\_\_\_\_

4. If the length is 9 meters and the width is 6 meters, what is the area?

Answer: \_\_\_\_\_

## AREA QUICK CHECK #2

1. What is the area of this shape?

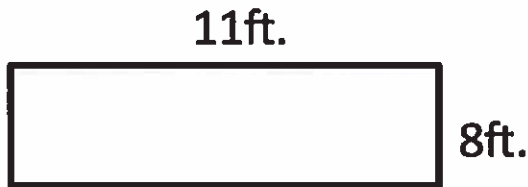

Answer: \_\_\_\_\_

2. Mike needs to tile his bathroom. His bathroom is 8 feet by 7 feet. How much tile does he need to cover the area of his bathroom?

Answer: \_\_\_\_\_

3. What is the area of this shape?



Answer: \_\_\_\_\_

4. If the length is 6 meters and the width is 3 meters, what is the area?

Answer: \_\_\_\_\_

For problems 1-4, find the missing side length.

1.

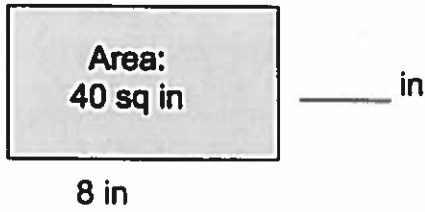

2.

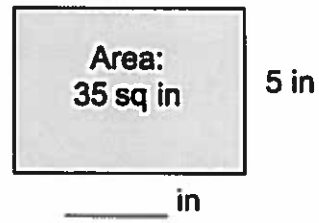

3.

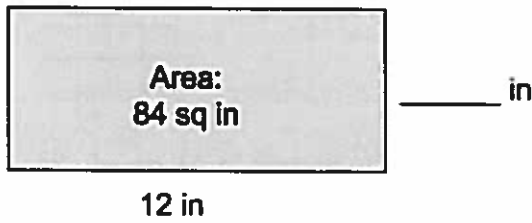

4.

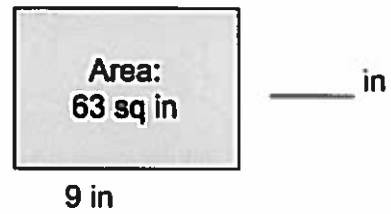

4. The following shaded figure is made up of 2 rectangles. Find the total area of the shaded figure.

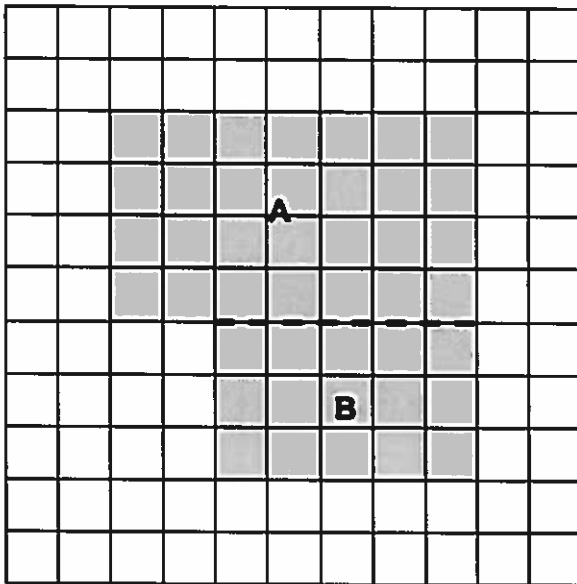

Area of A + Area of B = \_\_\_\_\_ + \_\_\_\_\_  
= \_\_\_\_\_ sq units

5. Bobby draws a 7 cm by 9 cm rectangle on her grid paper. She shades a square with a side length of 4 cm inside her rectangle. What area of the rectangle is left unshaded?

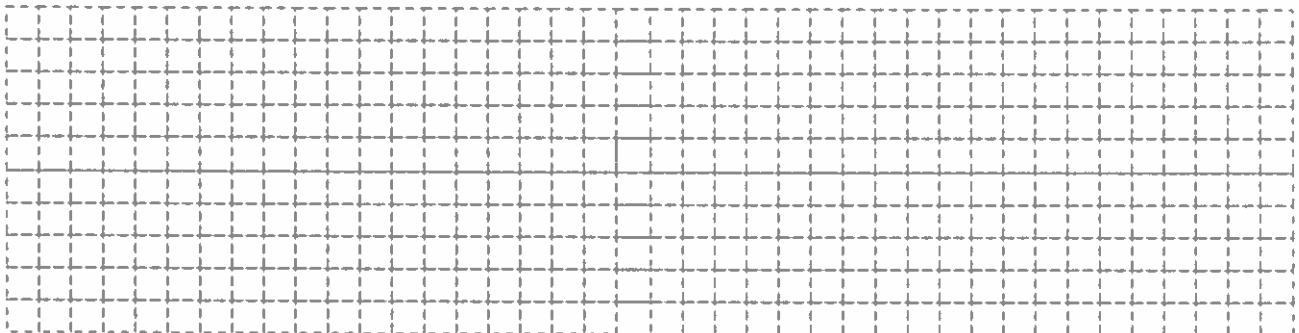

6. The area of a rectangle is 54 square units. One side has a length of 9 units. What is the other side length? Explain how you know using pictures, equations, and words.

7. Half of the rectangle to the right has been tiled with unit squares.



a. How many more unit squares are needed to fill in the rest of the rectangle? How do you know?

b. What is the total area of the large rectangle? Explain how you found the area.

8. Rectangles are joined together to make the following figure. Find the total area.

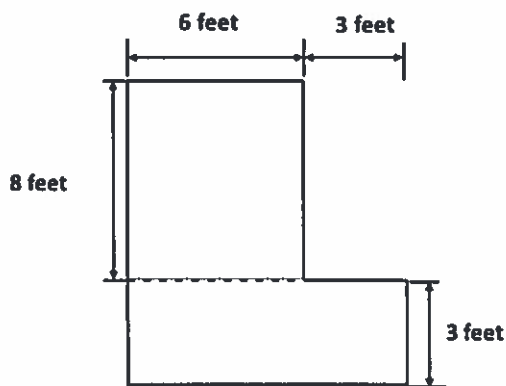

**Directions:** Use the mathematician plan and be sure to show your work for all possible answer choices.

**1. Which situation explains  $6 \times 4$ ?**

- a. A family with 4 children has a total of 6 people in it.
- b. There are 6 cookies, and you eat 4 of them.
- c. You buy 6 binders for \$4 each.
- d. You have \$6, and your mom gives you \$4 more.

**2. Which situation explains  $24 \div 8$ ?**

- a. A total of 24 slices of pizza are divided among 8 hungry people.
- b. There are 24 houses, and each has 8 windows.
- c. You have 24 baseball cards, and you buy 8 more.
- d. Your vacation lasts 8 days, and each day has 24 hours.

**3. Ms. Nelson evenly distributes 32 crayons to 8 kindergarteners. How many crayons does each student get?**

- a. 3 crayons
- b. 4 crayons
- c. 6 crayons
- d. 8 crayons

**4. Calculate the missing number in  $4 \times ? = 20$ .**

- a. 4
- b. 5
- c. 6
- d. 7

5. Round 437 to the nearest ten.

- a. 400
- b. 430
- c. 440
- d. 500

6. Calculate  $381 + 54$ .

- a. 335
- b. 435
- c. 721
- d. 921

7. Which fraction is represented by the darkly shaded area?

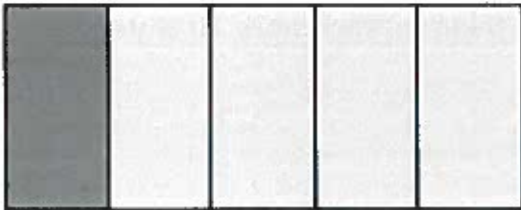

- a.  $\frac{1}{5}$
- b.  $\frac{4}{5}$
- c.  $\frac{5}{4}$
- d.  $\frac{5}{1}$



8. Which point represents the fraction  $\frac{1}{4}$  on the number line below?

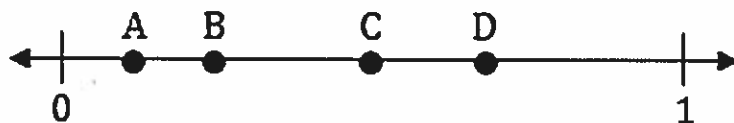

- a. Point A
- b. Point B
- c. Point C
- d. Point D

9. Karen takes a 30-minute lunch break starting at 12:15. At what time should she come back from her lunch break?

- a. 12:30
- b. 12:35
- c. 12:40
- d. 12:45

10. A penny has a mass of about 3 grams. What is the approximate mass of 6 pennies?

- a. 9 grams
- b. 12 grams
- c. 15 grams
- d. 18 grams

